

Overview

The design to widen Corkscrew Road from Ben Hill Griffin Parkway to Alico Road, a distance of 4.4 miles, is underway. The design of the four-lane facility will consist of two phases: Phase 1 is Ben Hill Griffin Parkway to Bella Terra Boulevard and Phase 2 is Bella Terra Boulevard to Alico Road.

History

The Corkscrew Road Service Area (CRSA) was created in the 1990's to assess property owners along Corkscrew Road east of I-75 for improvements to the road. The special assessment was established through a series of Board resolutions and was divided into two parts. The first part of the assessment was used to four-lane Corkscrew Road from I-75 to Ben Hill Griffin Parkway. This widening was completed in 1997. The second part of the assessment was intended to four-lane Corkscrew Road from Ben Hill Griffin Parkway to the Bella Terra entrance.

The County moved forward with design and permitting for the four-lane project from Ben Hill Griffin Parkway to the Bella Terra Entrance and acquired the needed right-of-way from the adjacent properties. The project was put out to bid for construction in 2006. Insufficient funding was generated from the CRSA assessment to cover the bid price, so a second assessment to a large number of homeowners and businesses would have been necessary to fulfill the obligation.

The Board of County Commissioners voted not to move forward with the four-laning project after residents and businesses objected to the additional assessment that would have been required of them for the project to proceed. Another factor in the decision to delay the project was the roadway conditions did not meet the need for four-laning at that point in time.

The current design update and revisions and the construction are being paid for by road impact fees and other developer contributions, gas taxes and loans.

Project Design Status

The Traffic Study has been completed which provided information about traffic signals and types of median openings. Please see the table below for median treatments.

Ben Hill Griffin Parkway	Remains the same	Traffic signal
The Shoppes at Grande Oaks	Remains the same	Right-in/right-out
Stoneybrook Golf Drive	Remains the same	Traffic signal
Grande Oak Way	Remains the same	Directional opening
Fire House Lane	Remains the same	Full median opening
Water Treatment Plant Access	Remains the same	Right-in/right-out
FP&L Access	Remains the same	Right-in/right-out
Palermo Lake Court	Change	Directional opening with right-in/right-out and eastbound to northbound left turn lane
Wildcat Run Road	Remains the same	Full median opening
WildBlue Blvd./entrance to Corkscrew Crossing	New	Full median opening
Cypress Shadows Blvd.	Remains the same	Full median opening
Bella Terra Blvd./Midnight Blue Court	Remains the same	Traffic signal
Wayside Lane/Panther Island Blvd.	Remains the same	Full median opening
Corkscrew Woods Parkway	Remains the same	Full median opening
Alico Road	Under evaluation	

The updated traffic projections also indicated a need for future six lanes not contemplated in the previous design. The design for Corkscrew Road includes four typical sections shown below. Section A will be six lanes from Ben Hill Griffin Parkway to Fire House Lane and then transition to a four-lane roadway east to Alico Road. The portion of the roadway from Fire House Lane to Bella Terra Boulevard will be expandable to six lanes in the future. Section D from Bella Terra Boulevard to Alico Road is expected to be four lanes. The roadway medians will vary from 22-44 feet and will have Lee County Core Level landscaping and street lighting.

Typical Section A

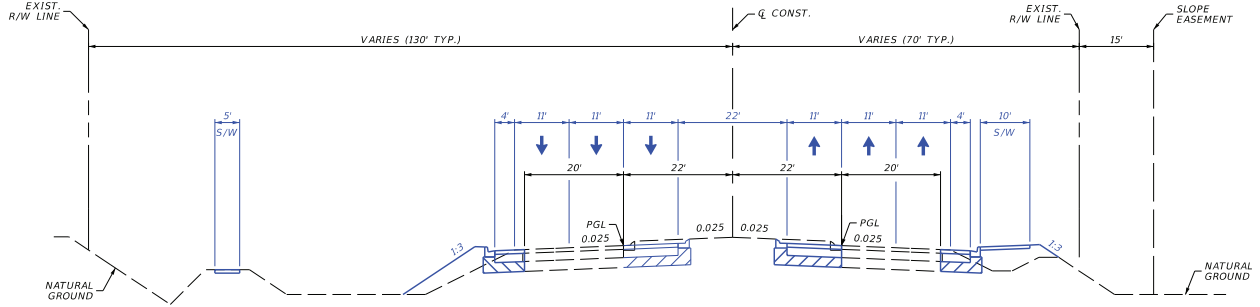

TYPICAL SECTION A
BEN HILL GRIFFIN PARKWAY
TO FIRE HOUSE LANE
PHASE I



Typical Section B

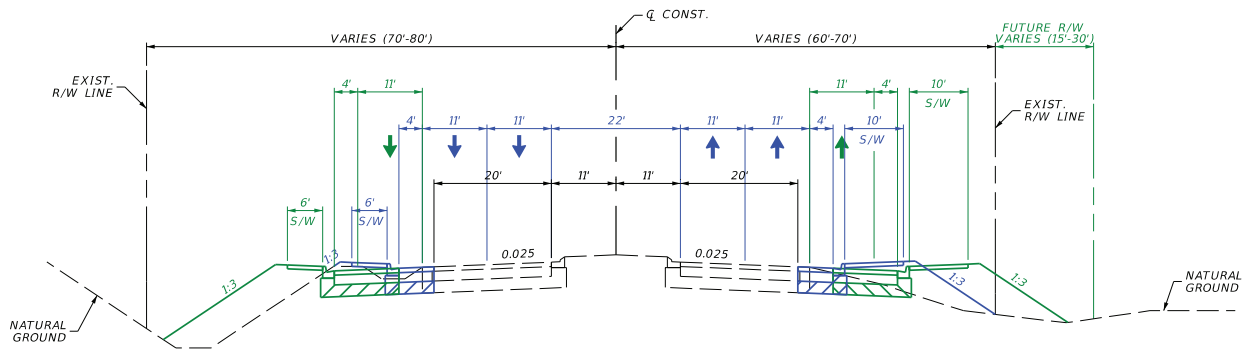

TYPICAL SECTION B
FIRE HOUSE LANE TO
EAST SIDE OF WILDCAT RUN
PHASE I

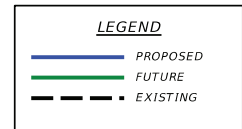

Typical Section C

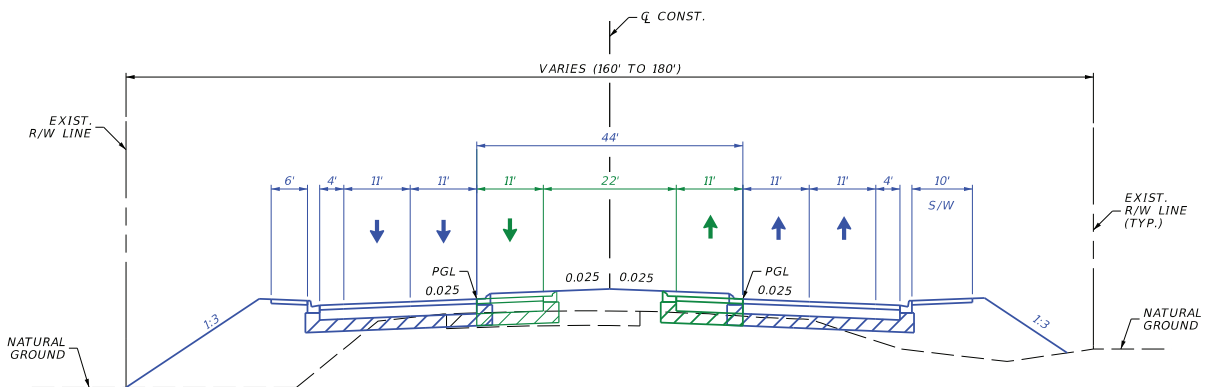

TYPICAL SECTION C
EAST SIDE OF WILDCAT RUN
TO BELLA TERRA BOULEVARD
PHASE I

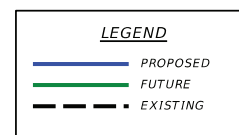

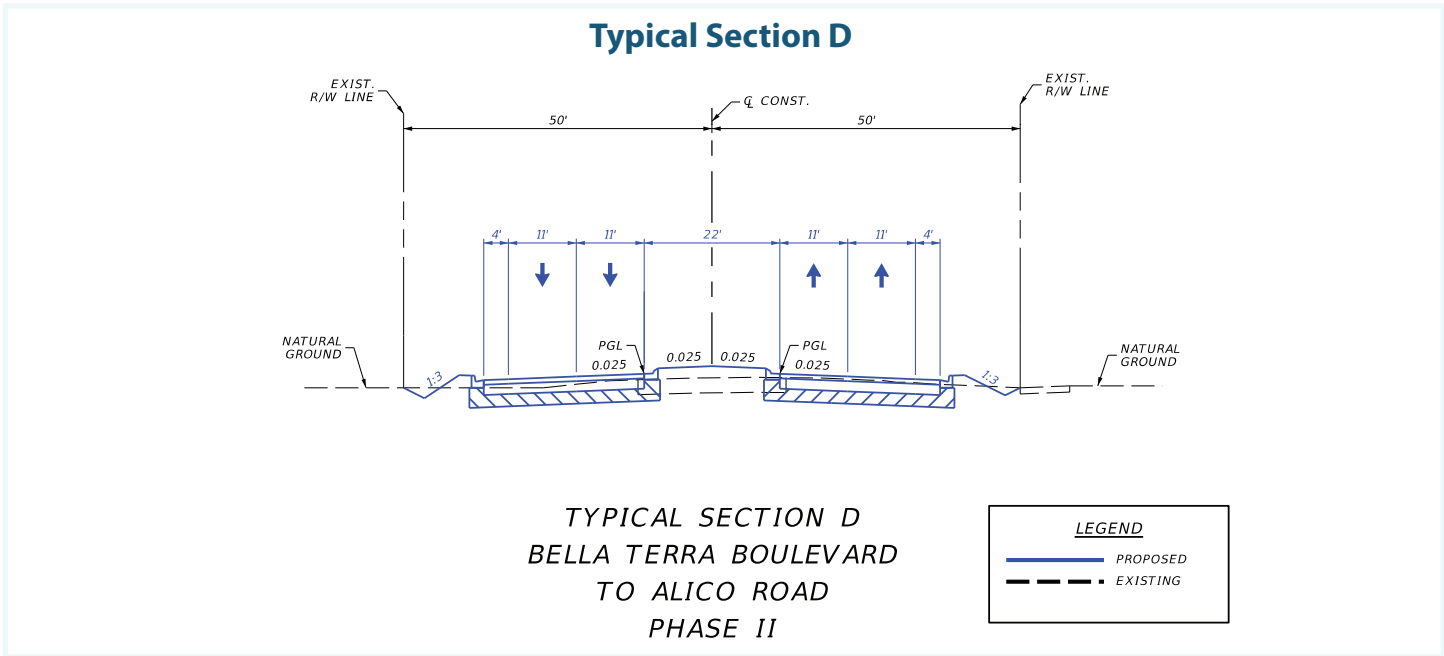

Construction

Phase 1 construction is anticipated to begin in late 2020/early 2021. The Phase 2 construction schedule is currently unknown due to the permitting and right-of-way acquisition efforts needed, but funds are budgeted for construction in fiscal year 2022/2023.

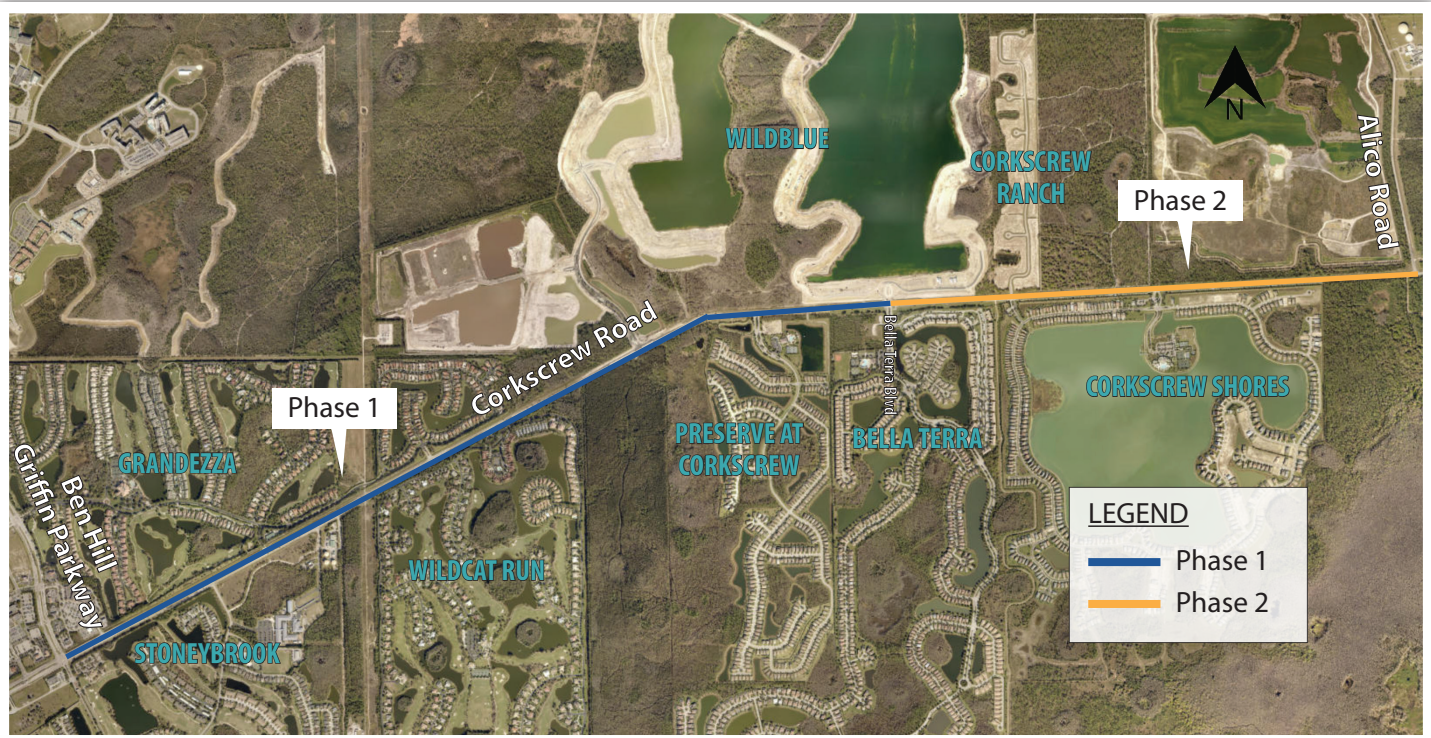

Public Involvement

The project team has scheduled meetings with the Homeowners' Association Boards for Grandezza, Stoneybrook, Wildcat Run, The Preserve at Corkscrew, and Bella Terra. A public meeting will be held in January 2020. On the project website, www.CorkscrewRoadWidening.com, there is information about the project, FAQs and an email form to submit comments or sign up for email blasts.