



# Street Light Standard

---

David Willems, PE

# Existing Decorative

Coconut Road (Brooks)



# Existing Decorative

Three Oaks Parkway (Brooks)



# Existing Decorative

Pelican Colony Blvd



# Existing Decorative

---

Via Villagio



# Existing Decorative

---

Paradise Shoppes



# Existing Decorative

Estero Grande



# Existing Decorative

---

Tidewater





# Existing Decorative

Old Winn-Dixie Plaza

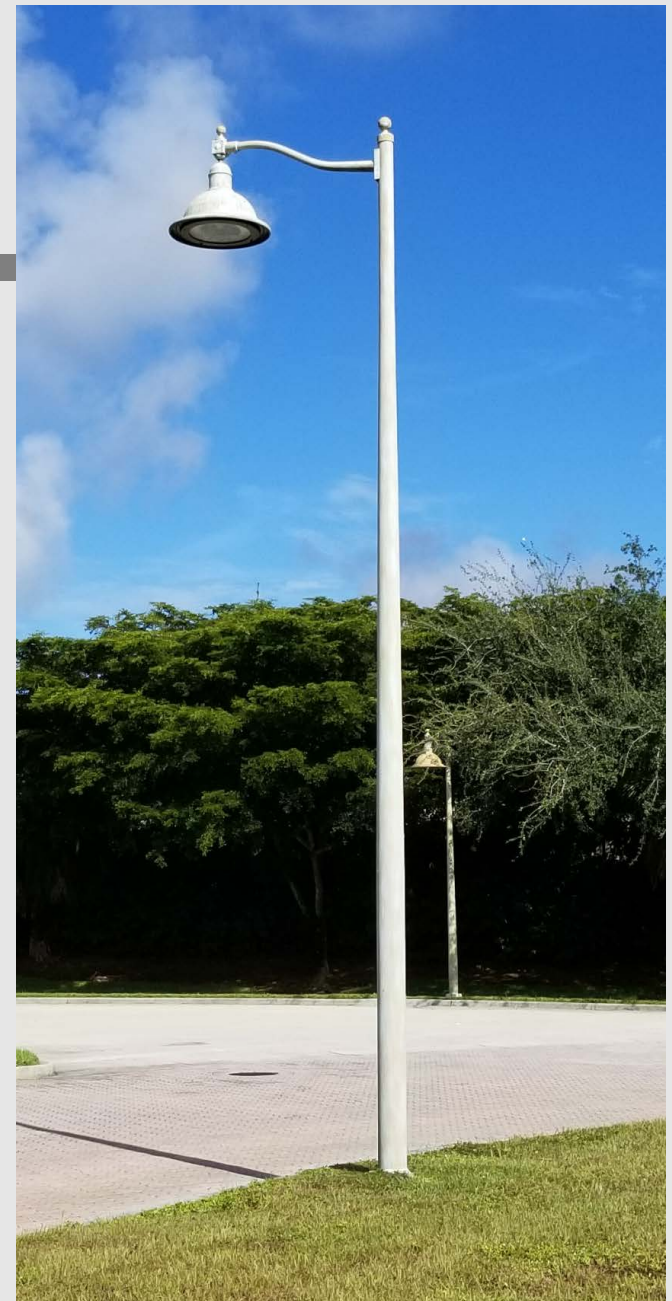

# Existing Decorative

Estero Parkway 7-11



# Existing Non-Decorative

Colonial East of I-75



# Existing Non-Decorative

Ben Hill Griffin



# Existing Non-Decorative

Corkscrew Road



# Existing Non-Decorative

## Estero Parkway



# Existing Non-Decorative

Three Oaks Parkway



# Existing Non-Decorative

Colonial East of I-75





# Standard

---

Build upon some of the great street/area lights we already have

- Bell shaped fixture
  - Matches many of the existing fixtures in Estero
- Side mounted fixture
  - Matches Three Oaks, Coconut, Pelican Colony & Via Villagio
  - Will distinguish Estero from other municipalities that use pendant fixtures
- Arms are generally simple
- Poles are generally simple with some having decorative bases
- Colors vary

# Fixture

---

Side Mounted  
Cyclone Domia



# Pole & Base

---

Tapered aluminum pole with decorative base



# Arm

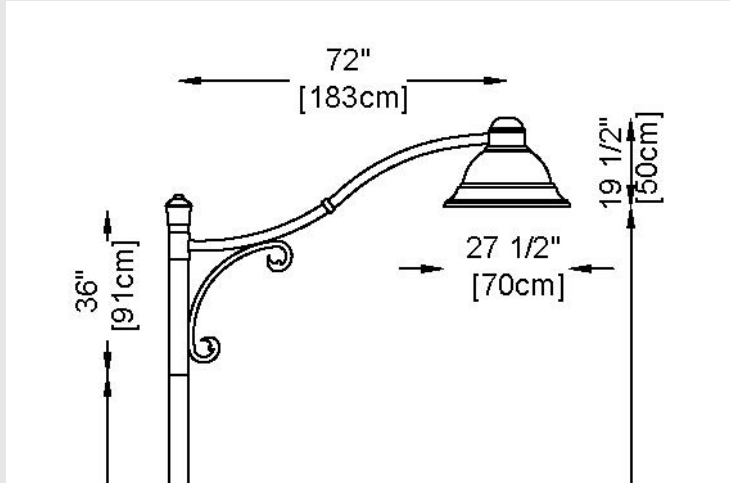

Option 1

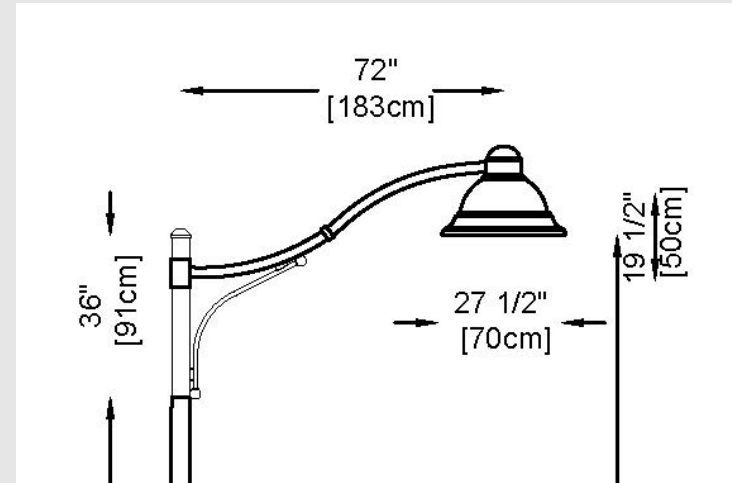

Option 2

# Arm

---

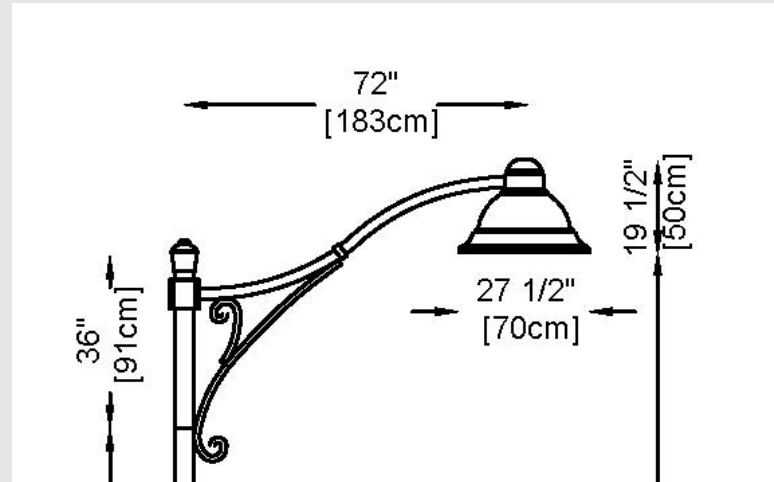

Option 3

# Options - Complete

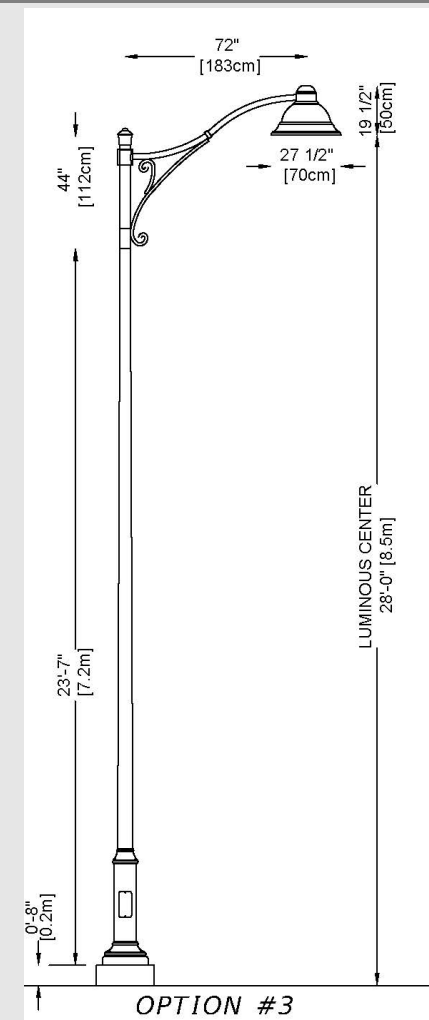
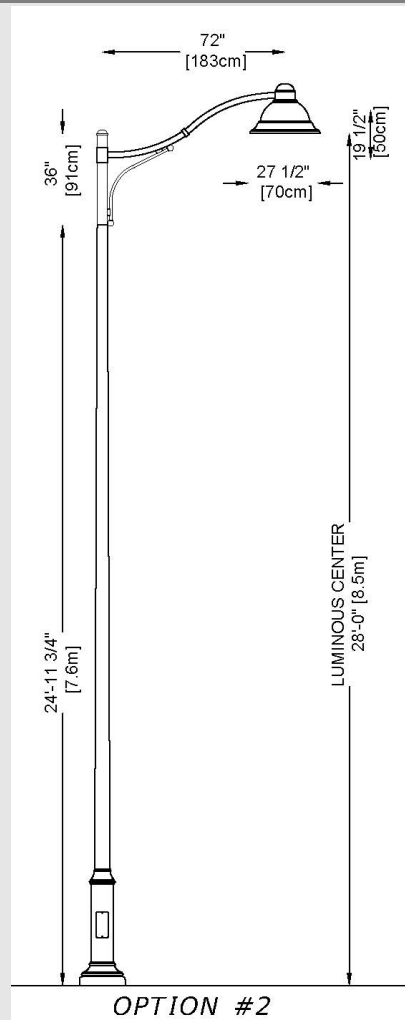
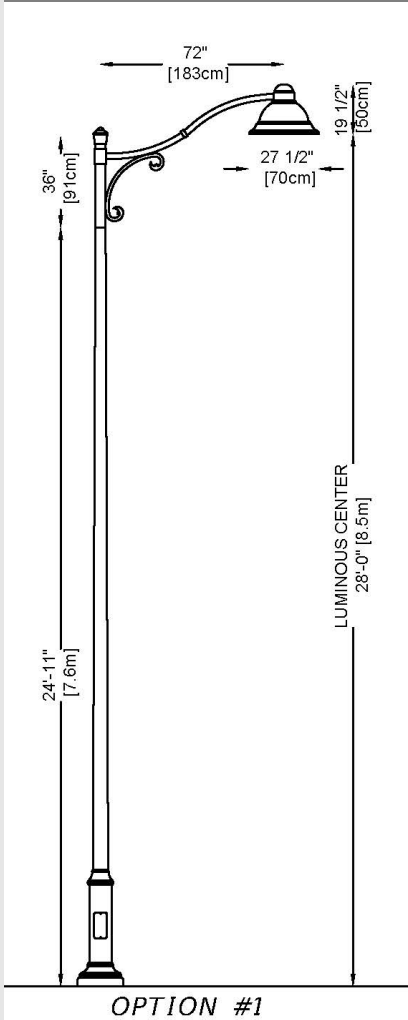

# Color

---

Dark Bronze

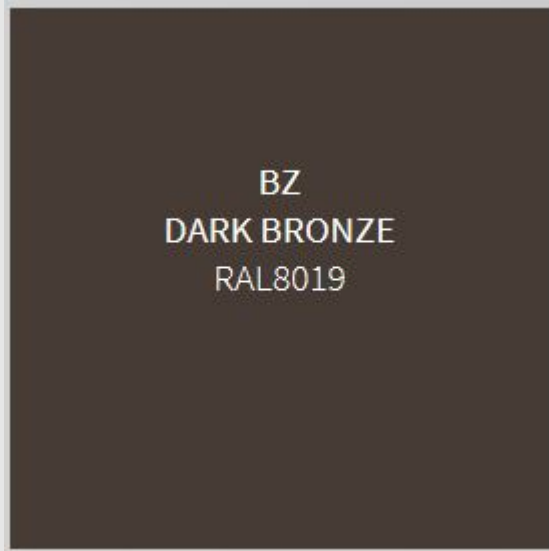

Black

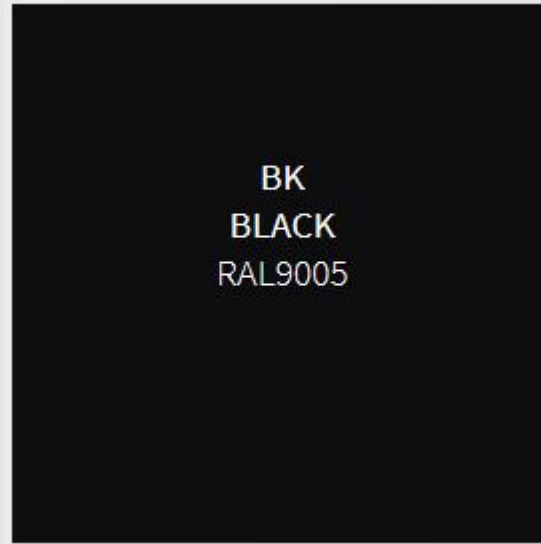

Green

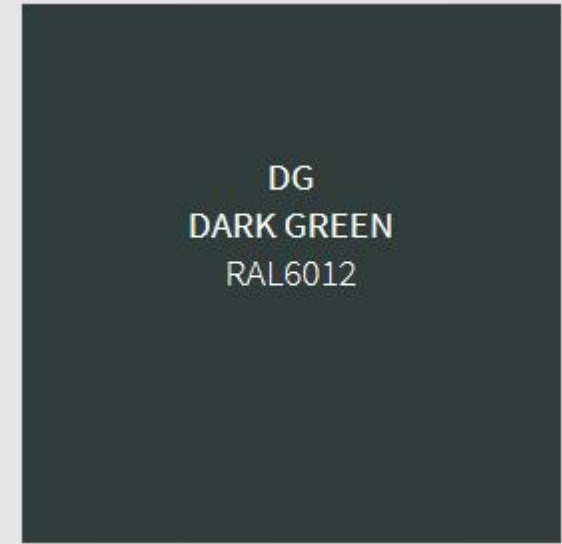

# Color

---

Dark Bronze



Black



Green





# Installation Costs – Estero Pkwy

Option	Total Cost	Cost Per Pole
Decorative Lights	\$997,126	\$9,406
Lee County Standard	\$848,726	\$8,007
Lease (Decorative)*	\$1,819,723	\$17,167

\*20-year lease at 6.75%

# Reoccurring Cost

---

## Decorative Street Lights

- Power - \$7.20 per month (\$86.4 /yr.)
  - Maintenance/Repair - \$5.00 per month (\$60/yr.)
  - Repaint - \$500 every 5-10 years (\$100/yr.)
  - Total per year - \$246.40
- 
- Estero Parkway (106 poles)
    - \$26,118.4/yr.
    - \$14,510/yr.-mile

# Reoccurring Cost

---

## Lee County Standard

- Power - \$7.20 per month (\$86.4 /yr.)
  - Maintenance/Repair - \$5.00 per month (\$60/yr.)
  - Total per year - \$146.40
- 
- Estero Parkway (106 poles)
    - \$15,518/yr.
    - \$8,621/yr.-mile

# Reoccurring Cost

---

## Leasing (Decorative lights)

- Power - \$7.20 per month (\$86.4 /yr.)
  - Maintenance/Repair - \$5.00 per month (\$60/yr.)
  - Repaint - \$500 every 5-10 years (\$100/yr.)
  - Total per year - \$246.40
- 
- Estero Parkway (106 poles)
    - \$26,118.4/yr.
    - \$14,510/yr.-mile

# Cost Summary

Option	Installation Cost per mile	Annual Cost per mile	20-year Cost per mile
Decorative Lights	\$553,960	\$14,510	\$844,160
Lee County Standard	\$471,514	\$8,621	\$643,934
Lease (Decorative)*	\$0	\$65,058	\$1,301,157

\*20-year lease at 6.75%

# Potential Village Wide Cost

---

## Decorative Street Lights

- Installation Cost - \$553,960/mile
- Annual Cost - \$14,510/yr.-mile

## Approx. 14.75 miles of roadway

Estero Pkwy, Corkscrew, Three Oaks, Ben Hill & Via Coconut/Sandy Broadway, Williams & Coconut counted as half due to roadway width

- Installation Cost - \$8,171,000
- Annual Cost - \$214,100/yr.

# Questions?

---

