

EXHIBIT "A"
DESCRIPTION TO ACCOMPANY SKETCH
A PARCEL OF LAND LYING
IN SECTION 28

TOWNSHIP 46 SOUTH, RANGE 25 EAST
LEE COUNTY, FLORIDA

SEE SHEET 1 OF 2 FOR SKETCH TO ACCOMPANY THIS DESCRIPTION

NOT A BOUNDARY SURVEY

DESCRIPTION: (PER HARRIS-JORGENSEN, LLC)

A TRACT OR PARCEL OF LAND LYING IN BLOCKS D AND C AND ADJOINING VACATED STREET OF TRAIL ACRES, ACCORDING TO A PLAT RECORDED IN PLAT BOOK 7, PAGE 46 OF THE LAND RECORDS OF LEE COUNTY, FLORIDA, WHICH TRACT OR PARCEL OF LAND IS DESCRIBED AS FOLLOWS:

BEGINNING AT A CONCRETE MONUMENT MARKING THE SOUTHEAST CORNER OF SAID BLOCK D, THENCE RUN S.89°49'11" W. ALONG THE NORTH RIGHT-OF-WAY LINE OF BROADWAY AVENUE E. (70 FEET WIDE) FOR 150.00 FEET; THENCE RUN N.00°45'23" W. FOR 310.33 FEET; THENCE RUN N.89°49'11" E. FOR 150.00 FEET; THENCE RUN S.00°45'23" E. TO THE AFORESAID SOUTHEAST CORNER BLOCK D, ALONG THE NORTH RIGHT OF WAY LINE OF BROADWAY AVENUE E. FOR 310.33 FEET TO THE POINT OF BEGINNING.

CONTAINING: 46,485.32 SQ. FT OR 1.06 ACRES, MORE OR LESS.



PHILLIP M. MOULD
PROFESSIONAL SURVEYOR AND MAPPER
#6515 - STATE OF FLORIDA
09/11/2018

SKETCH TO ACCOMPANY DESCRIPTION:

**A PARCEL OF LAND LYING
IN SECTION 28**

TOWNSHIP 46 SOUTH, RANGE 25 EAST
(O.R. BOOK 3315, PAGES 4428-4429)
LEE COUNTY, FLORIDA

SEE SHEET 2 OF 2 EXHIBIT "A" FOR
DESCRIPTION TO ACCOMPANY THIS SKETCH

****NOT A BOUNDARY SURVEY****

LANDS OF PALM VILLA APARTMENTS, LLC.
(STRAP No. 28-46-25-E2-UI923.2494)
LOT 10 BLOCK C

N.89°49'11"E. 150.00'

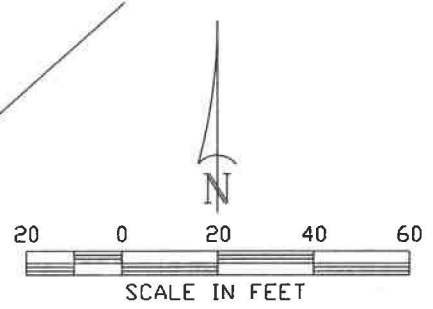

LOT 9 BLOCK C

NORTHEAST DRIVE
(VACATED)

BOUNDARY LINE AGREEMENT
(O.R. BOOK 1605, PAGE 1202)

10' NATURAL VEGETATIVE BUFFER
(O.R. BOOK 1605, PAGE 1202)

LOT 8 BLOCK D

LANDS OF PALM VILLA APARTMENTS, LLC.
(STRAP No. 28-46-25-E2-UI923.2494)
N.00°45'23"W. 310.33'

(O.R. BOOK 3315, PAGES 4428-4429)

EAST LINE OF BLOCK "D" (PLAT BOUNDARY)

S.00°45'23"E. 310.33'

LANDS OF NOBLES
(STRAP No. 28-46-25-E2-UI930.2496)

LOT 7 BLOCK D

LOT 6 BLOCK D

LOT 2 BLOCK D

LOT 3 BLOCK D

LOT 4 BLOCK D

LOT 5 BLOCK D

POINT OF COMMENCEMENT
POINT OF BEGINNING
S.E. CORNER OF
LOT 5 BLOCK D

NORTH R/W LINE

S.89°49'11"W. 150.00'

35.00'

35.00'



BROADWAY AVENUE E.
(70' R/W)

LEGEND:

- O.R. OFFICIAL RECORDS BOOK
- P.O.B. POINT OF BEGINNING
- P.O.C. POINT OF COMMENCEMENT
- R/W RIGHT-OF-WAY
- ⊕ CENTERLINE

SHEET 1 OF 2

SKETCH TO ACCOMPANY DESCRIPTION
SEE EXHIBIT "A" FOR DESCRIPTION
TO ACCOMPANY THIS SKETCH
"NOT A BOUNDARY SURVEY"

DRAWN: PMM	CHECK: FBH	SCALE 1"=40'	PROJ. # 811BROADWAY
SURVEY DATE 6/18/18		FILE NO. 46-25-28	SHT.- 1 OF - 1

HARRIS-JORGENSEN, LLC
3046 DEL PRADO BLVD. S.
3A
CAPE CORAL, FLORIDA 33904
(239)-257-2624